

®ICP PiezoVelocity sensor Model 111 Top Connector

Main Characteristics

- 100 mV/ips or 4 mV/mm/s
- -55°C to 120 °C (-67°F to 248°F)
- ®ICP transmission mode
- Annular shear mode
- Dual case isolation with Faraday shield
- IP67 with associated cable (B=2, 3 only)

Competitive advantage

- Annular shear mode is less susceptible to base strain.
- Ultra low noise electronic
- Miswiring and surge protections
- Low cost IP67 overmolded M12 cable assembly
- M12 overmolded cable assembly is available through local electronic distributor
- M12 offers compatibility with sensors used in automation.

Description

The hermetic sealed industrial piezovelocity transducer model 111 is design to monitor the vibration in harsh industrial environment. It uses the industry standard ©ICP 2-wire voltage transmission technique with a 4 mA standard constant current supply. Signal ground is isolated from the mounting surface and outer case to prevent ground loops. Faraday shielding will limit sensitivity to EMC to a minimum. Annular shear mode design will prevent from thermal transient and base strain. Low noise electronic and a temperature compensated design will give you accurate result over the complete temperature range.

Typical applications

Velocity is the preferred measurement for most rotating machines with rolling element bearings. Unfortunately it is sometimes impossible to get velocity (with digital or analog integration) from standard piezoelectric accelerometer : very high frequency noise can overload the accelerometer and saturate the output. Piezovelocity sensors use an internal integration circuit which inherently decrease high frequency signals allowing better measurement of low frequency signal. Paper machine dryers (when steam leaks), pumps (cavitation high frequency noise) are prone to such phenomenom.

Ordering information model 111.01

To order, specify model number, options and suffix :

111.01- A - B (CC-DD) - Options - Accessories

A : Sensitivity (Suffix)

- 6 : 100 mV/ips (4mV/mm/s)
- Available suffix : N, negative polarity

B : Connector / Integral cable

- 1 : *MIL-C-5015, glass seal
 - 2 : *M12 glass seal
 - 3 : M12 epoxy sealed
 - 5 : *Integral cable
 - 7 : *Integral cable with stainless steel overbraid protection
 - 8 : Integral cable with stainless steel protection conduit
- Option 5, 7, 8 needs additional information :(CC-DD)
Options 3, 5, 7, 8 are not stocked. Leadtime : 2 to 4 weeks.

CC : Cable Type (only integral cable B=5, 7, 8)

- 01 : *Polyurethane twisted pair cable (90°C)
- 02 : *Teflon FEP twisted pair Cable (200°C)
- 03 : Radox twisted pair cable (120°C, halogen free)
- 12 : Teflon FEP twisted triple Cable (200°C). For TO option.
- 13 : Radox twisted triple (120°C, halogen free). For TO option
- 31 : *Polyurethane 4 conductors cable (90°C). For T0 option

DD : length in metre (only integral cable B=5, 7, 8)



Model 111.01-A-2 with Overmolded M12 cable assembly

Options :

Housing thread (Standard thread : M6x1)

- H1 : M16x2 (quick mouting + 120° positioning) (Not stocked)
 - H2 : Quick fit mounting (Not stocked)
 - H7 : 1/4" 28 UNF-2A. (Not stocked)
- option H2 and H1 are recommended for integral cable.
option H7 is available for North American market.

Temperature output

- T0 : 10 mV/°C. (+2° to +120°C)
- Not available with Mil-C-5015 2 pins connector

Special Agency Approval

none

Accessories (Machine thread):

- M6 : M6x1 mounting stud
- M7 : 1/4" 28 UNF 2A mounting stud
- M8 : M8x1.25 mounting stud
- W6 : Swivel adaptor

Special Engraving :

- Add ZXX at the end of the part number.
- XX is a number supplied by VibraSens

* Most Popular model :

111.01-6-2 / 111.01-6-1

Ordering example :

111.01-6-1M6 Piezovelocity sensor, MIL 5015 glass seal top connector

Specifications (24°C)

Dynamic

Sensitivity A=6..... 100 mV/ips ±10% (4 mV/mm/s)

Frequency response (fig. 4a, 4b)

A=6 ±10 % : 2.5 to 3500 Hz

..... ±3 dB : 1.9 to 7000 Hz

Mounted Resonant frequency A=6 16 kHz Nom

Dynamic range A=650 in/sec pk (1250 mm/sec)

Transverse response sensitivity (20Hz, 5g) <5%

Temperature response fig3

Polarity (fig. 1) Suffix dependant

Linearity ±1% Max

Warm up time (Typical) A=6 < 5Sec

Electrical

Electrical Grounding Isolated from machine ground

..... Internal Faraday shielding (fig. 1)

Isolation(Case to shield) 100 MΩ Min

Capacitance to ground..... 70 pF Nom

Output impedance 200 ΩNom

DC output bias, 4mA supply 10 VDC (Fig 2)

Residual noise (24°C) : A=6

2.5 Hz to 25 kHz 100 µin/sec

10 Hz 10 µin/sec

1000 Hz 0.1 µin/sec

Power requirements Constant current : +2 to +10mA DC

Voltage : +22 to +28 VDC

Protection : Overvoltage Yes

: Reverse polarity Yes

Environmental

Temperature, operating continuous (max. current =4mA)

..... -55 to 120 °C (-65 to 250 °F)

Humidity / Enclosure

B=1, 2 Not affected, hermetically sealed, 1E-8torr.l/s

B=3 IP67, epoxy sealed

Acceleration limit : Shock 2 500g peak

: Continuous vibration 250g peak

Base strain sensitivity 0.004 in/sec/µstrain

Mean time between failure (MTBF) 10 Years Nom

ESD Protection > 40 V

Safety EN 61010-1 and IEC 1010-1

EMC emission EN 50081-1, EN 50081-2

EMC immunity (1) EN 50082-1, EN 50082-2

Physical

Dimensions

B=1 Fig. 1a

B=2 Fig. 1b

B=3 Fig. 1c

B=5 Fig. 1d

B=6 Fig. 1e

Design Ceramic, preloaded annular shear mode

Weight A=6 95 gr Nom (3.4 Oz)

Connector

B=1 MIL-C-5015 glass seal, Type MS3143 10SL-4P

B=2 M12 glass seal, IEC 60947-5-2

B=3 M12 epoxy seal, IEC 60947-5-2

Material AISI 316L, DIN 1.4401 (Stainless steel)

Sensor mounting thread Fig 1h

Mounting torque (M6, M7, M8 suffix) 2,4 N.m (21 in-lbs)

Accessories, supplied

Calibration supplied

..... Sensitivity (5 in/sec, 160 Hz)

..... No frequency response

Accessories, not supplied

Cable assembly

MIL connector (B=1), Polyurethane cable..... 10.01-B01-A01-01-Length

MIL connector (B=1), FEP Teflon cable..... 10.01-B01-A01-02-Length

M12 connector B=2, 3 Polyurethane cable 10.01-E01-A01-31-Length

PU or FEP Armored cables are also available. See Model 10.01.

Mounting Stud

M6 191.01-06-06-1

1/4" 28 UNF 191.01-06-16-1

M8 191.01-06-08-1

Repair

Consult factory for replacement of connector in case of broken or bended pins. Repair of electronic is not possible.

Standard Wiring color

With Mil-C-5015 cable assembly: + = Red // - = White

With M12 cable harness: : + = Black // - = Blue // Temperature=White

(1) Guaranteed if using accessories listed in this product datasheet only

Drawings

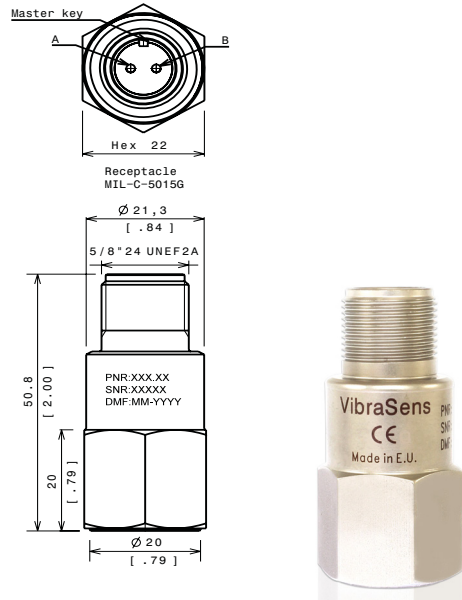

Model Number	Pin A	Pin B
Standard, no option	(+)	(-)
T0 Option (10mV/°C)	N/A	N/A

(N/A) : Not available

Fig 1a : Outline drawing & Electrical layout, B=1 (MIL-C-5015)

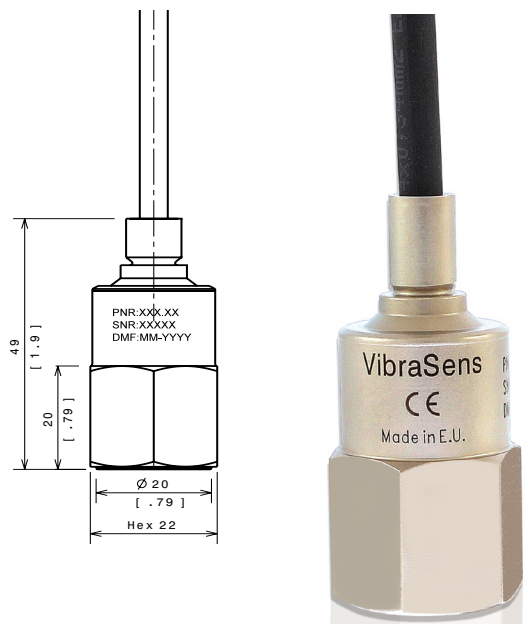
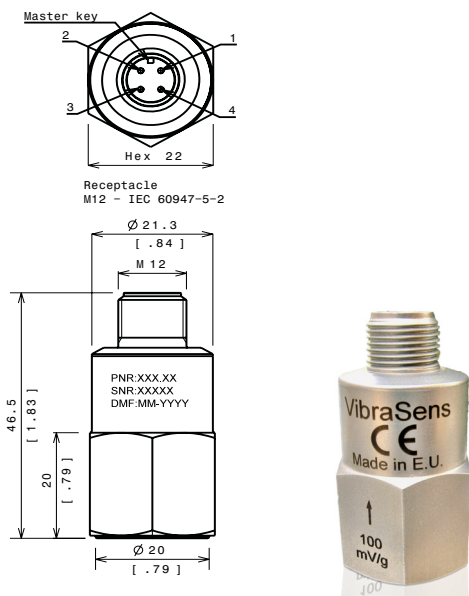

Model Number	Pin 1	Pin 2	Pin 3	Pin 4
Standard, no option	NC	NC	(-)	(+)
T0 Option (10mV/°C)	NC	(Temp)	(-)	(+)

(NC) : Not connected

fig 1b : Outline drawing & Electrical layout, B=2 (M12 glass seal)

CC=01, 02 (PU, Teflon)	White (-) / Red (+)
CC=03 (Radox)	White N°1 (-) / White N°2 (+)
CC=12 (Teflon) (1)	White (-) / Red (+) / Black (Temp.)
CC=13 (Radox) (1)	White N°1 (-) / White N°2 (+) // White N°3 (Temp)
CC=31 (PU) (1)	Blue (-) / Black (+) / White (Temp.) / Brown (NC)

(1) T0 option (10mV/°C)

Fig 1d : Outline drawing & Electrical layout, B=5 (cable only)

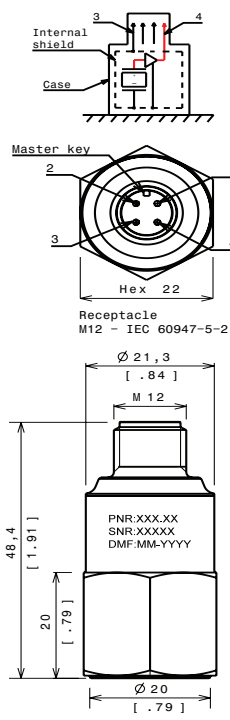

Fig 1c : Outline drawing B=3 (M12 Epoxy)
electrical layout : See above B=2

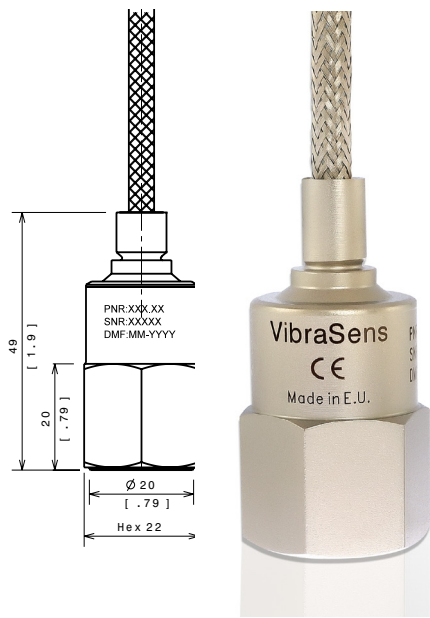

Fig 1e : Outline drawing B=7 (cable with overbraid)
electrical layout : See above B=5

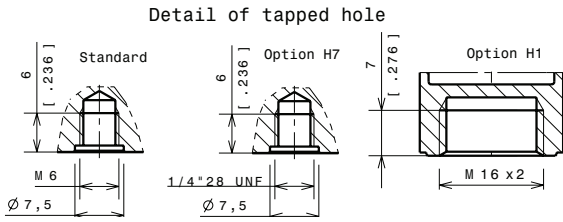

Fig 1h : Housing thread, option H1, H2, H7

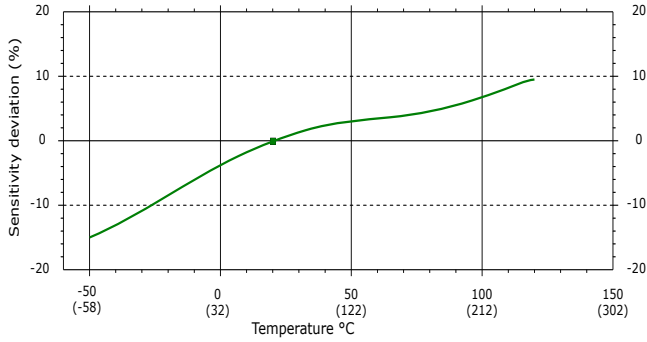

Fig 2 : DC (Bias) deviation versus temperature

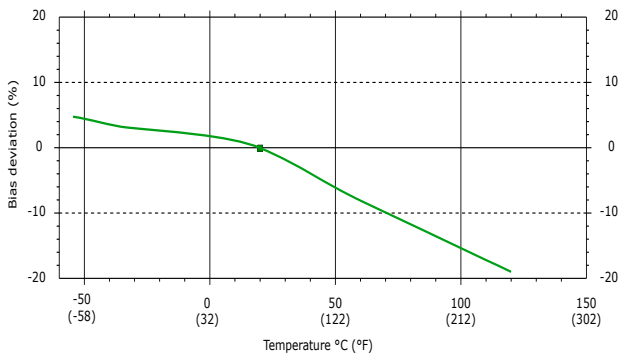

Fig 3 : Sensitivity deviation versus temperature

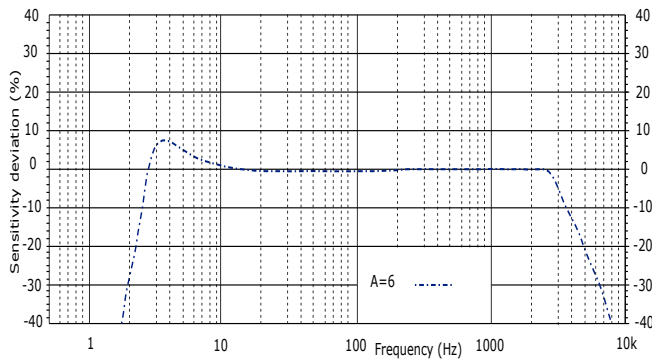

Fig 4a: Frequency response, amplitude

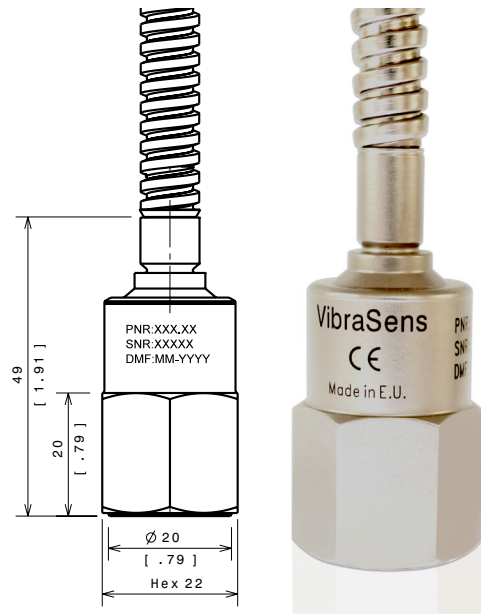

Fig 5 : Outline drawing B=8 (cable with conduit protection)
electrical layout : See above B=5