

Cementing - Adhesive pad, Model 204

Main Characteristics

- Permanent mounting
- For industrial top connector accelerometer
- Stainless steel (AISI 303)

Description

Cementing pads are used for permanent installations. It eliminates tapping into the structure but provide high frequency capability approaching stud mount. The pad is epoxied in place of the tapped hole; the sensor is then mounted to the pad. Cementing - adhesive pads can provide additional electrical isolation. Adhesive selection is critical for long term reliability. Our cemented pads feature a flat abraded mounting surface for superior bonding and a stud (M5, 10-32 UNF, M6 or 1/4" 28 UNF) for mounting the accelerometer.

Ordering information

To order, specify part number, options and suffix :

204.01- AA - BB - C

AA : Sensor thread

- 05 - M5x0.8
- 15 - 10-32 UNF
- 06 - M6x1
- 16 - 1/4" 28 UNF

BB : Diameter

- 13 - 13 mm
- 19 - 19 mm
- 22 - 22 mm

C : Material

- 1 - AISI 303

Stocked models :

204.01-15-17-1 / 204.01-06-22-1 / 204.01-16-22-1

Ordering example

204.01-06-22-1 Adhesive pad, M6, AISI 303

Specifications

Environmental

Temperature depends on adhesive

Physical

Dimensions See outline drawing Fig 1a

Weight

204.01-XX-17-1 5.5 gr (~ 0.19 Oz)

204.01-XX-22-1 9.5 gr (~ 0.33 Oz)

Material Stainless steel AISI 303

Accessories

Adhesive Loctite 330

Competitors cross reference list

Wilcoxon SF8, SF8-2 / CTC online MH130-1A, MH133-1A / AMPO ERD20 (not stainless steel)



Model 204.01-06-22

Outline drawing

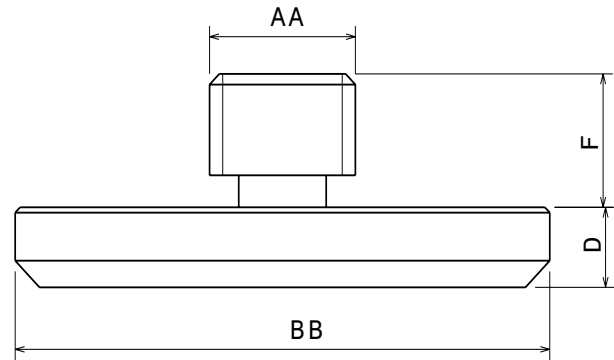

Fig 1a

Model	F (mm)	D (mm)	Application
204.01-15-17-1	3.2	3	Model 108
204.01-06-22-1	4.3	5	Model 101, 105
204.01-16-11-1	4.3	5	101, 105 with H7 option

Mounting drawing

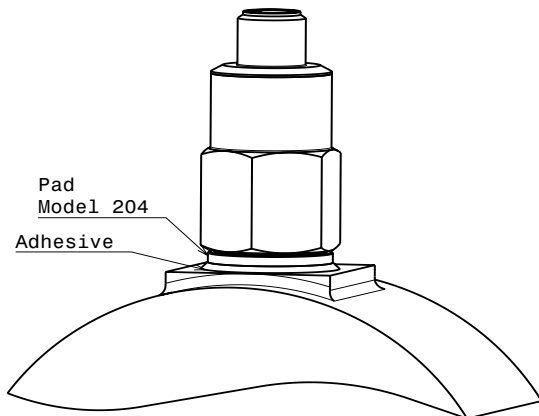

Fig 2a