

Flat magnet, Model 211

Main Characteristics

- portable route measurements
- for top connector vibration sensors with M6 and 1/4" 28 UNF thread
- for flat surfaces only (to be used whenever possible with our magnet targets)
- stainless steel

Description

The use of magnet bases is convenient and quick for many applications (route measurements). They produce an intimate and stiff contact between DC and few kilohertz. The high frequency response (above few kHz) is significantly distorted. Obviously the machine surface should be magnetically attractive and free of paint chips and scale. Painted surface should use our stainless steel magnet target model 208 that greatly improves the high frequency response. We also recommend the use of coupling fluids, such as oil.

Customer should pay attention to magnet attaching on the machine. The shock could overload the vibration sensor and destroy the electronic.

Ordering information

To order, specify part number, options and suffix :

211.01- AA - BB

AA : Sensor thread

06 M6x1
16 1/4" 28 UNF

BB : Diameter

25 25 mm

Stocked models :

211.01-06-25 / 211.01-16-25

Ordering example

211.01-06-25 Flat magnet, M6

Specifications

Dynamic
Frequency response 10% : DC to 2.5 kHz
..... see fig 4a

Environmental
Temperature -55°C to 160 °C (-67°F to 320°F)

Physical
Dimensions See outline drawing Fig 1a
Weight ~ 42 gr (~ 1.5 Oz)
Material Stainless steel
Magnet high temperature rare earth magnet
Pull force 23 kg (50 Lbs)

Accessories
Magnet targets model 208

Competitors cross reference list

Wilcoxon B3 / CTC online MH103-1B - MH136-1A / PCB 080A121 (080A120) / AMPO
EMID 22 (very low pull force) / Dytran



Model 211.01-06-25

Outline drawing

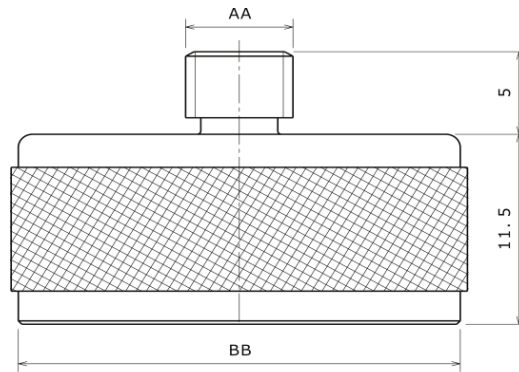

Fig 1a

Mounting drawing

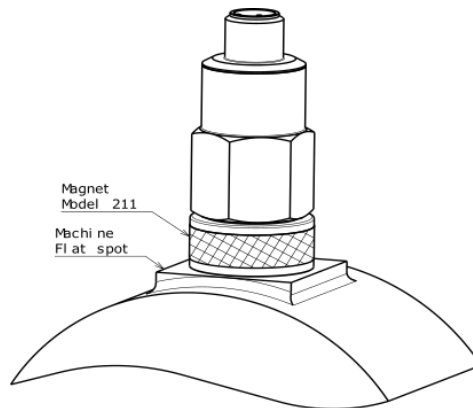

Fig 2a

Typical frequency response

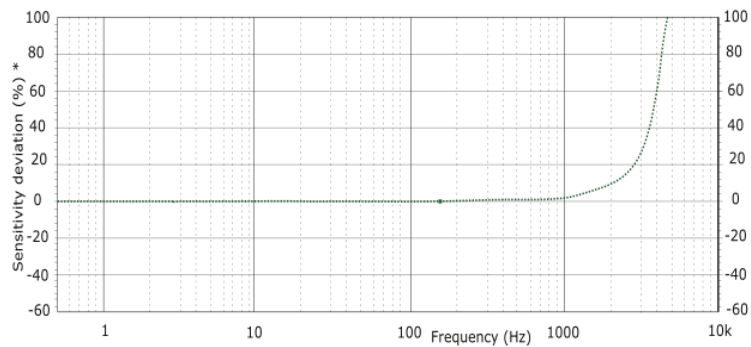

Fig 4a